

About this Manual

We've added this manual to the Agilent website in an effort to help you support your product. This manual is the best copy we could find; it may be incomplete or contain dated information. If we find a more recent copy in the future, we will add it to the Agilent website.

Support for Your Product

Agilent no longer sells or supports this product. Our service centers may be able to perform calibration if no repair parts are needed, but no other support from Agilent is available. You will find any other available product information on the Agilent Test & Measurement website, www.tm.agilent.com.

HP References in this Manual

This manual may contain references to HP or Hewlett-Packard. Please note that Hewlett-Packard's former test and measurement, semiconductor products and chemical analysis businesses are now part of Agilent Technologies. We have made no changes to this manual copy. In other documentation, to reduce potential confusion, the only change to product numbers and names has been in the company name prefix: where a product number/name was HP XXXX the current name/number is now Agilent XXXX. For example, model number HP8648A is now model number Agilent 8648A.

Installation Guide

Publication number E5374-92001
November 1998

© Copyright Hewlett-Packard Company 1997-1998
All Rights Reserved

Elastomeric Probe Adapter for Hitachi SH7709

Installation at a Glance

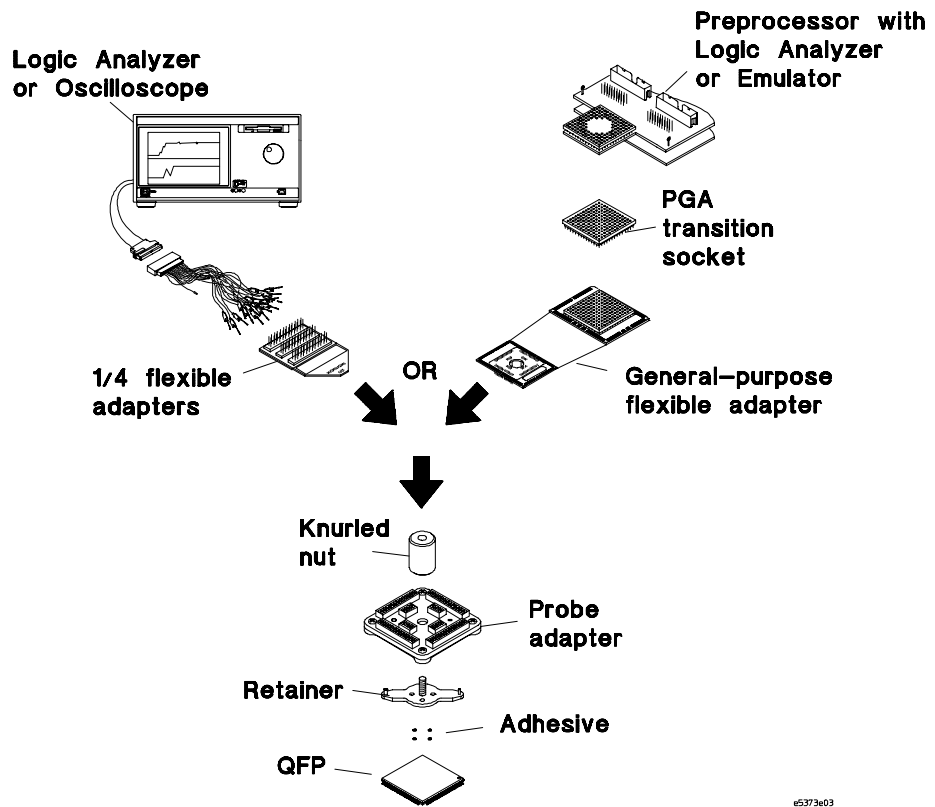

This Installation Guide explains how to use Hewlett-Packard's advanced probing system for 0.5 mm pitch Quad Flat Pack (QFP) surface-mounted integrated circuits. This probing system provides a quick and reliable connection from these devices to Hewlett-Packard oscilloscopes, logic analyzers, and emulators.

This information also explains how to use optional flexible adapter cables that will enhance the adapter's use in particular probing situations. Drawings are included to help you in laying out printed circuit boards with the proper component spacing to allow correct use of the adapter.

In This Book

1	Installing the probe adapter	
2	Installing optional flexible adapters	
3	Reference	

This manual is organized in three chapters.

Chapter 1 contains the procedure for installing the probe adapter onto your QFP.

Chapter 2 contains the instructions for installing optional flexible adapters.

Chapter 3 contains reference information such as pinout and cross-reference maps, additional or replaceable parts lists, retainer and adhesive removal.



This chapter includes the procedure for installing the probe adapter onto your QFP. The major steps are:

- 1 Prepare to attach the retainer to the QFP 1-3
- 2 Test the alignment before adhering the retainer 1-4
- 3 Adhere the retainer to your QFP 1-7
- 4 Install the probe adapter 1-10

Installation of the Elastomeric Probe Adapter

To install the QFP elastomeric probe adapter

You should have the items shown in the following illustration to install the probe adapter. Installation will take about 20 minutes.

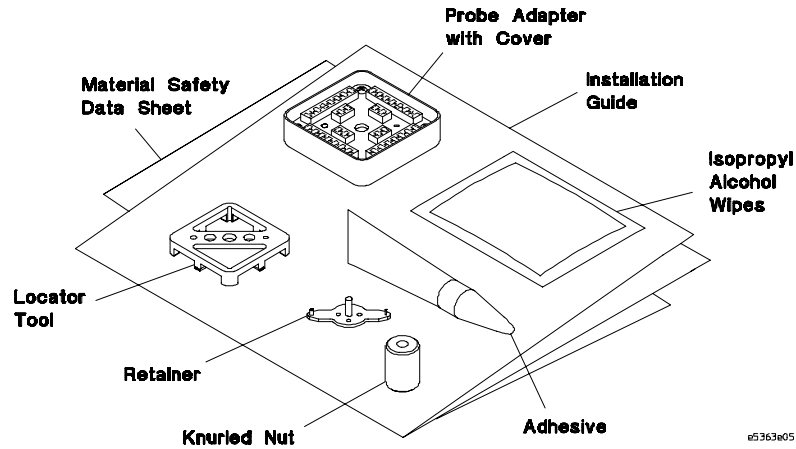

Electrical Characteristics

Operating Voltage	< 40 V (dc + Peak ac)
Operating Current	0.5 Amps Maximum
Insulation Resistance	> 100 M Ω

Model Parameters:

Capacitance between Contacts	0.5 pF (Typical)
Self-Inductance	10 nH (Typical)
Contact Resistance	< 0.25 Ω (Typical)
Operating Bandwidth	dc - 750 MHz (Typical)

Environmental Characteristics

Operating Temperature	0 $^{\circ}$ C to 55 $^{\circ}$ C
Maximum Operating Humidity	75% Relative Humidity

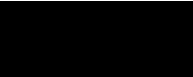

Prepare to attach the retainer to the QFP

- 1 Check the area around the package to be probed. The minimum required clearance from the package and any components is shown in the illustration below. The probe will work within the parameters shown.

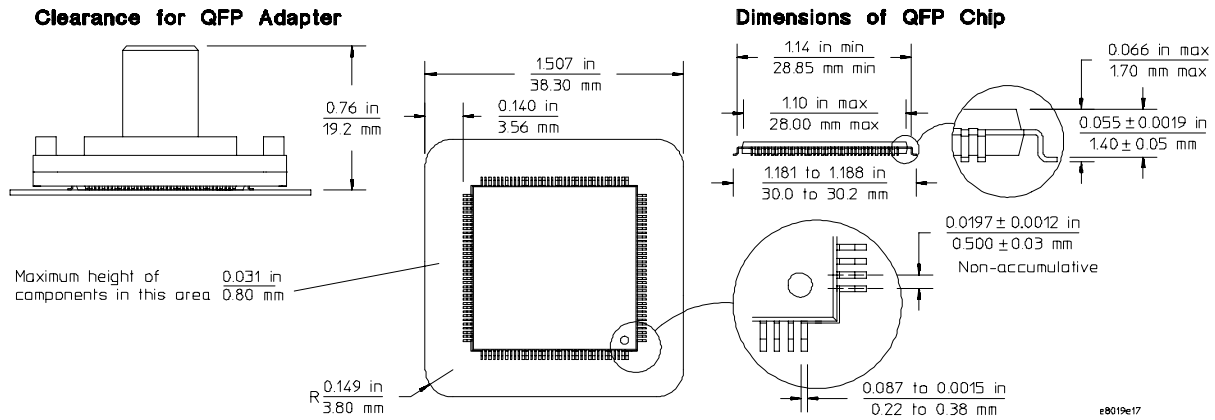

- 2 Assemble the locator and the retainer, using the knurled nut to hold them together.

Align the big and little pins of the retainer with the big and little holes of the locator tool.

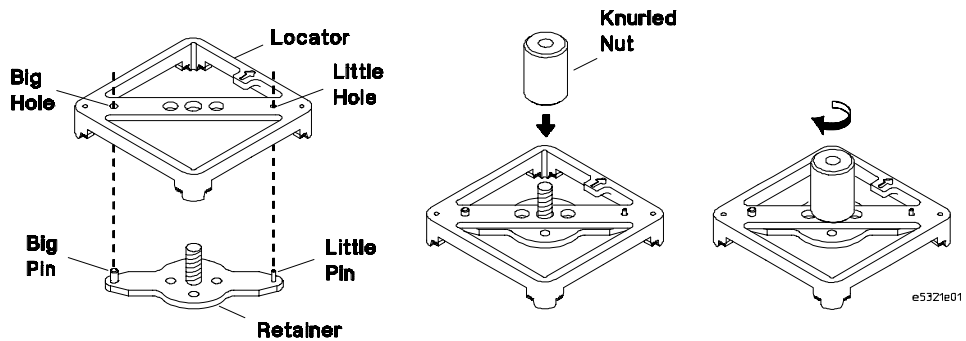

Test the alignment before adhering the retainer

CAUTION

Turn off the power to your QFP when using the metal locator tool. Failure to do so could cause damage to your IC.

CAUTION

Use grounded wrist straps and mats when installing or performing any service to your probe adapter. Electrostatic discharge can damage electronic components.

- 1 Align the little pin corner of the assembled locator tool with the pin 1 corner on the QFP.

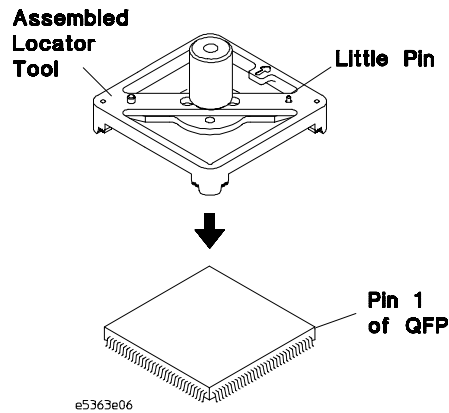

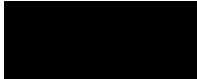

- 2 Place the assembled locator tool on the QFP, making sure that it aligns squarely. You will feel the teeth drop between the QFP legs when it is aligned.

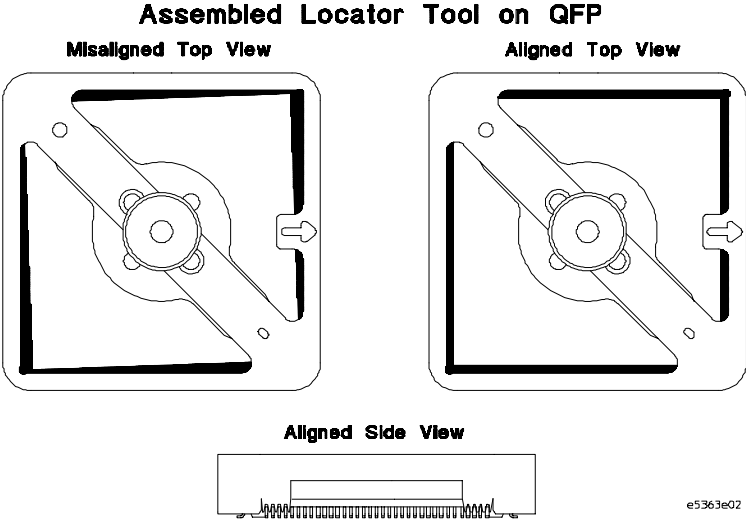

- 3 Press down on the middle of both sides of the locator tool.
If the tool is down far enough, it will not rock when pressed on the sides.

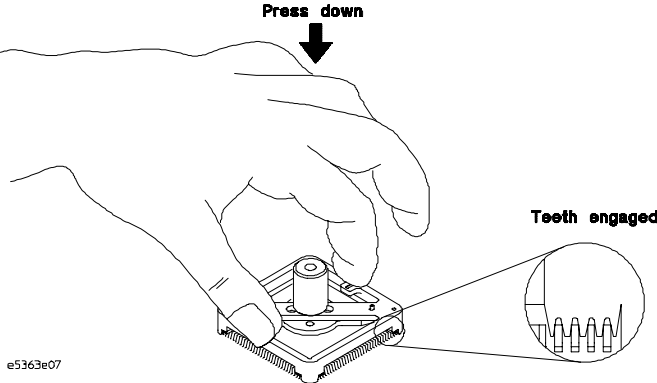

Installation of the Elastomeric Probe Adapter
Test the alignment before adhering the retainer

- 4 Remove the assembled locator tool and prepare surfaces before applying adhesive.
 - a Use a single edged razor (or equivalent) to remove foreign material, such as stickers or adhesive, from the top surface of the QFP.
 - b Remove any remaining debris from the top surface and legs of the QFP with precision dusting cleaner (also known as inert dusting gas or compressed air in a can).
 - c Clean the the bottom of the retainer, and the top surface and legs of the QFP by wiping with an Isopropyl Alcohol wipe provided in the Retainer Kit. Do not use other cleaners or solvents.

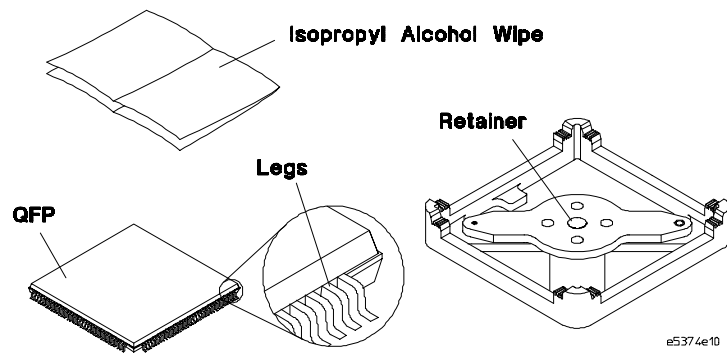



Adhere the retainer to your QFP

CAUTION

You will use adhesive to attach a retainer to the top of the QFP. The retainer ensures precise alignment between the probe adapter and the device. Read the following steps to understand the process of applying adhesive before doing them.

CAUTION

Make sure you can control the amount of adhesive. Excess adhesive can cause problems, so it is better to use too little than too much. Follow the manufacturer's recommended temperature parameters for the adhesive.

WARNING

Read the Material Safety Data Sheet enclosed for handling precautions on the Loctite 4204 Prism Instant Adhesive or call Loctite Corporation at (860) 571-5100.

Cyanoacrylate adhesive is a very fast setting and strong adhesive. It bonds human tissue including skin in seconds. Experience has shown that accidents due to cyanoacrylates are handled best by passive, nonsurgical first aid. Treatment of specific types of accidents are given in the data sheet.

- 1 Apply four small drops of adhesive to the underneath side of the retainer as shown.

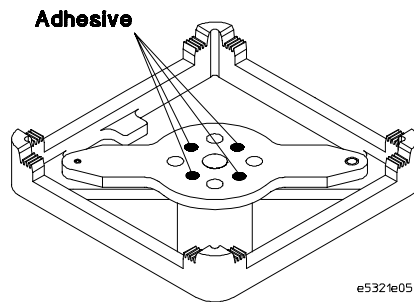

Installation of the Elastomeric Probe Adapter
Adhere the retainer to your QFP

CAUTION

Turn off the power to your QFP when using the metal locator tool. Failure to do so could cause damage to your IC

- 2 Place the locator tool on top of the QFP as you did to test the alignment.

The adhesive on the retainer will not touch the QFP until the next step and the adhesive will not solidify until the retainer and QFP touch, so there is plenty of time to adjust the tool if necessary.

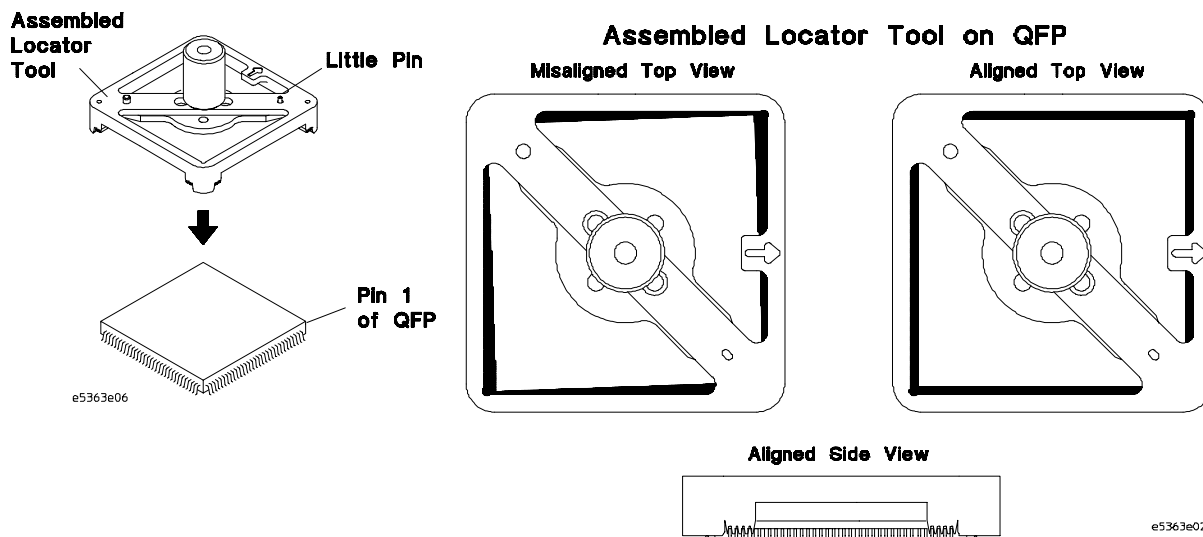

- 3 Hold down on the sides of the locator tool and loosen the knurled nut two turns. Continue to hold down on the sides of the locator tool and press down on the knurled nut to drop the retainer onto the top of the QFP. Hold for 45 seconds.

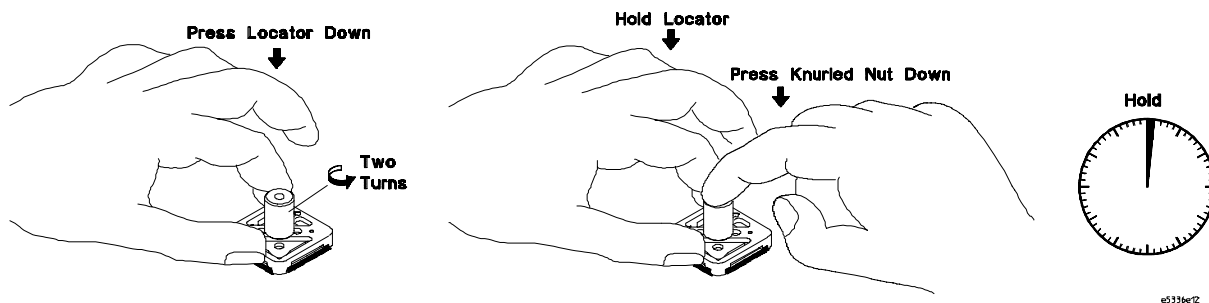



- 4 Wait 15 minutes for the adhesive to cure.

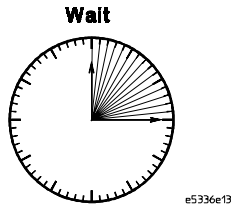

- 5 Remove the locator tool, by completely unscrewing the knurled nut and lifting the locator off the QFP.

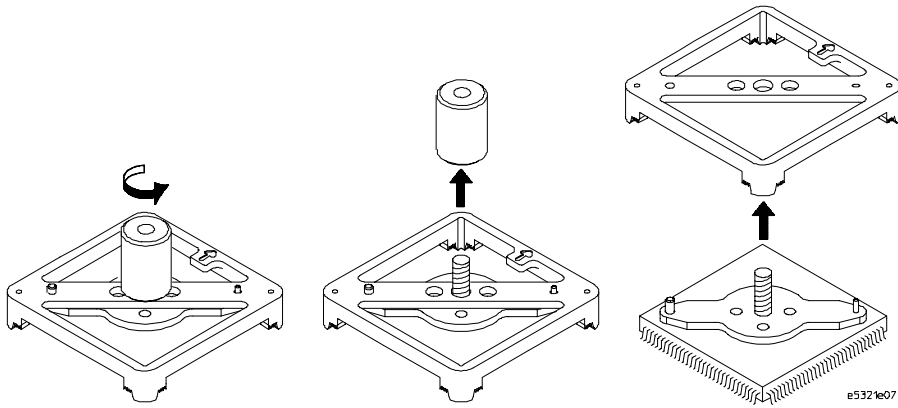

- 6 Remove any adhesive that leaked out the edges of the retainer, using a knife, so that the probe adapter will seat properly.

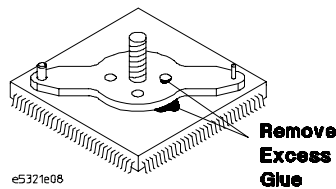

If a retainer ever breaks off of the QFP, a new retainer can be re-attached. There are some contaminants that are not removed with Isopropyl Alcohol in preparing the surfaces before adhering. If a retainer breaks off, the adhesive from the initial installation usually removes any remaining contamination. The bond strength of a second retainer is usually higher than the bond strength of the first. Repeat all steps in this section to re-attach a new retainer.

Install the probe adapter

- 1 If the probe adapter is already attached to the analysis probe (preprocessor) or emulator, go to the analysis probe (preprocessor) or emulator documentation for installation instructions.
- 2 Remove the cover.

When you store the probe adapter, put the cover back on to protect the conductive elastomer from dust or damage.

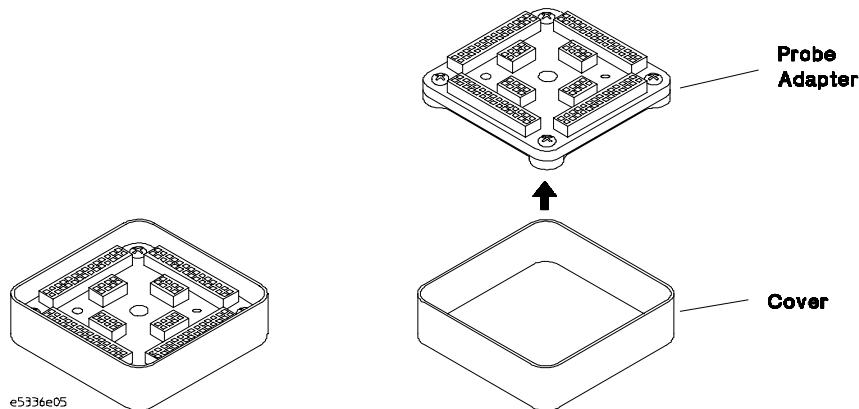

CAUTION

Do not touch the contact area on the conductive elastomer, which is on the bottom of the probe adapter. Contamination or damage to the conductive elastomer will cause shorts or poor contact.

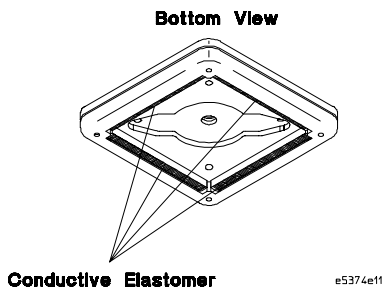

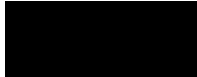

- 3 Install the elastomeric probe adapter on the retainer.
 - a Place the probe adapter over the retainer so that the threaded stud passes through the center hole of the adapter, and the dowel pins of the retainer enter the holes in the adapter.
 - b Avoid touching the elastomers to the threaded stud or dowel pins of the retainer as the probe is inserted.
 - c Make sure the dowels on the retainer are inserted in the holes on the probe adapter and that it is laying flat against the QFP before tightening the nut.
- 4 Turn the knurled nut until it stops.

CAUTION

Do not over-tighten the knurled nut. Over-tightening the nut will make it difficult to remove.

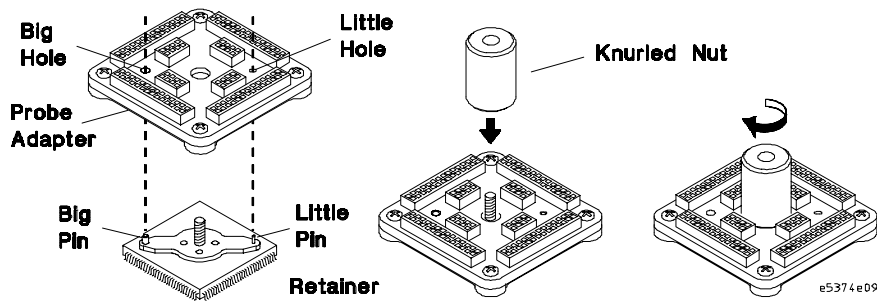

A pinout map showing the pin numbers of the probe adapter and your QFP is in the Reference chapter of this document.



This chapter includes procedures to install optional flexible adapters for use with Hewlett-Packard logic analyzers, oscilloscopes, and emulators.

- The HP E5371A 1/4 flexible adapters, 2-2
- The HP E5372A general-purpose flexible adapter, 2-5

Installation of Optional Flexible Adapters

The HP E5371A 1/4 flexible adapters

The HP E5371A 1/4 flexible adapters can be used with any Hewlett-Packard oscilloscope or logic analyzer. They provide a flexible mechanical interface while maintaining the electrical performance to the probe tip. They allow you to probe selected pins or every pin on your QFP. Use one to four flexible adapters depending on your needs.

Performance characteristics of the HP E5371A 1/4 flexible adapters

Used with HP E5374A 208-pin 0.5 mm
Elastomeric Probe Adapter

Electrical Characteristics

Operating Voltage < 40 V (dc + Peak ace)
 Operating Current 0.5 Amps Maximum
 Insulation Resistance > 100 M Ω

Model Parameters

Pin-to-Ground Capacitance 3.5 pF Typical First Row
 5.0 pF Typical Second Row
 8.0 pF Typical Third Row
 Pin-to-Pin Capacitance 2 pF Typical
 Self-Inductance 30 nH Typical First Row
 40 nH Typical Second Row
 50 nH Typical Third Row
 Operating Band width 350 Mhz Typical

Environmental Characteristics

Operating Temperature 0 °C to 55 °C
 Maximum Operating Humidity 75% Relative Humidity

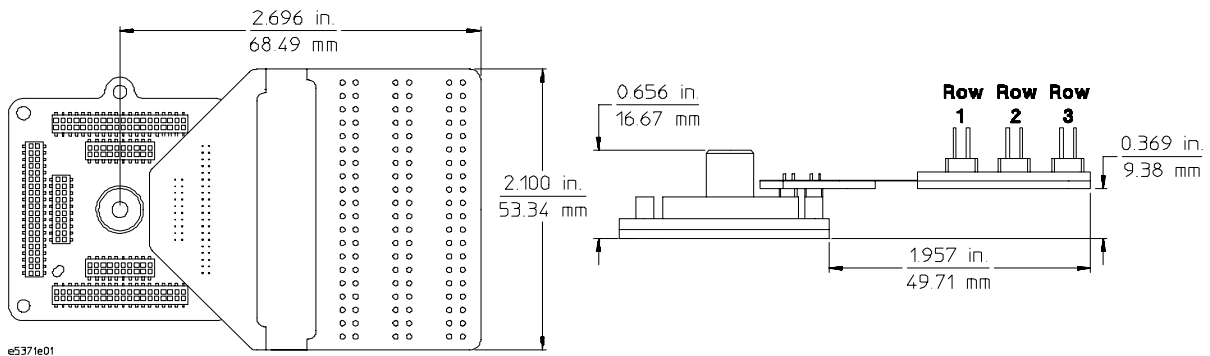



To connect an HP logic analyzer or oscilloscope using a 1/4 flexible adapter

- 1 Power-off the analysis probe (preprocessor), logic analyzer, and target system.
- 2 Follow the steps in chapter 1 to install the elastomeric probe adapter.

CAUTION

Damage to the QFP. Once the 1/4 flexible adapter has had its common pins connected to ground it should not be used in any other quadrant of the elastomeric probe adapter or in any other device. Remove the solder connecting the common pins to ground before reuse.

- 3 Put the supplied label(s) on your 1/4 flexible adapter(s) as shown in step 5.
- 4 Apply a small amount of solder across the gap between the signal pins that are ground on your device under test and the common pins of the 1/4 flexible adapter. This will facilitate the connection of the HP logic analyzer or oscilloscope probe ground.

All of the common pins are connected together through a grid on the bottom of the flexible adapter as shown below.

The pin numbers printed on the label correspond to the pins in one quadrant of the probe adapter. Refer to the pinout and cross-reference maps in the Reference chapter of this document when using multiple 1/4 flexible adapters.

Top View of 1/4 Flex

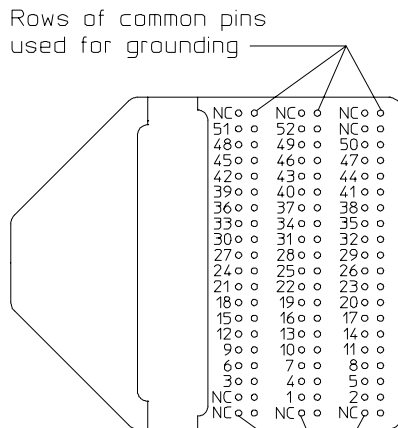

Bottom View of 1/4 Flex

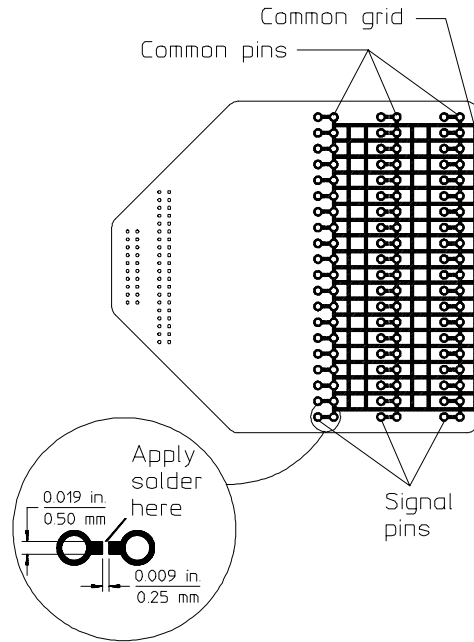

e5374e02

CAUTION

To prevent pin damage and ensure a proper connection, make sure the pins of the flexible adapter are aligned and seated correctly in the sockets on the probe adapter.

- 5 Plug 1 to 4 flexible adapters into the sockets on the top of the probe adapter assembly as shown in the following illustration.

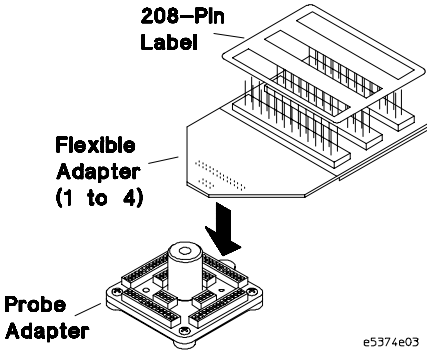

- 6 Connect the appropriate logic analyzer or oscilloscope probe to the correct circuit as indicated by the adapter pin numbers.

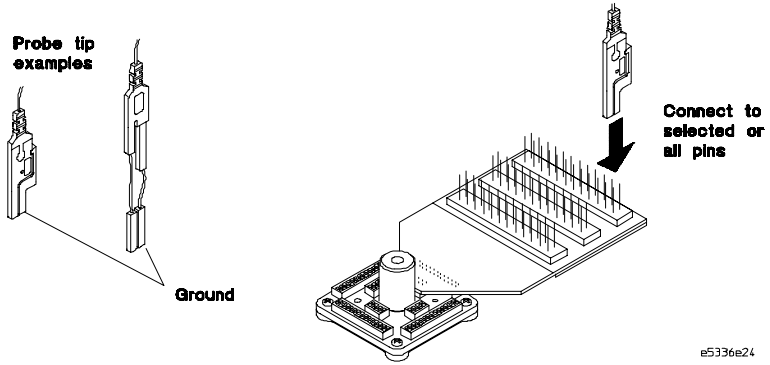

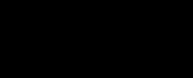

The HP E5372A general-purpose flexible adapter

The HP E5372A general-purpose adapter gives you access to predefined processor support for a Hewlett-Packard analysis probe (preprocessor) and logic analyzer or emulator.

Performance characteristics of the HP E5372A general-purpose flexible adapter

Used with Elastomeric Probe Adapter	HP E5374A 208-pin 0.55 mm	
Electrical Characteristics	Signal loading per line in addition to emulator or analysis probe (preprocessor) load	<5pF typical (no target grounds connected) 20 pF typical (with target grounds connected)
	Maximum operating frequency	33 MHz
Environmental Characteristics	Operating Temperature	0 °C to 55°C
	Maximum Operating Humidity	75% Relative Humidity

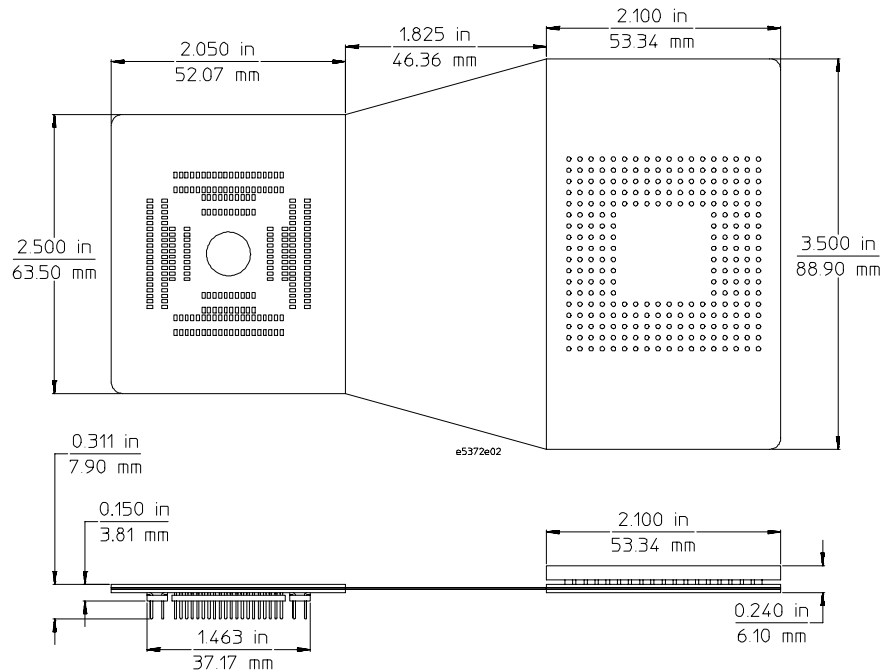

To connect an HP logic analyzer or oscilloscope using a general-purpose flexible adapter

- 1 Power-off the target system, analysis probe (preprocessor) and logic analyzer, or emulator.
- 2 Follow the steps in chapter 1 to install the elastomeric probe adapter.

CAUTION

Serious equipment damage. Ensure that the analysis probe (preprocessor) or emulator probe is aligned with the proper pins when connecting to the general-purpose flexible adapter. Serious equipment damage can result from improper connection. The final connection should match the orientation you select from your HP analysis probe (preprocessor) or emulator manual.

- 3 Refer to the orientation illustration in your HP analysis probe (preprocessor) or emulator manual to select one of four possible orientations.

The general-purpose flexible adapter can be attached to the probe adapter in one of four orientations to avoid interfering with tall components on the target system.

CAUTION

To prevent pin damage and ensure a proper connection, make sure the pins of the analysis probe (preprocessor) probe, transition board, general-purpose flexible adapter, and elastomeric probe adapter are aligned and seated correctly in the sockets.

- 4 Connect the analysis probe (preprocessor), transition board, general-purpose flexible adapter, and elastomeric probe adapter using the orientation selected in the previous step.

Refer to the pinout and cross-reference maps in the Reference chapter of this document for pin numbers on the general-purpose flexible adapter.

See Also

Refer to your HP analysis probe (preprocessor) or emulator manual for information on connecting to and using the analysis probe (preprocessor) or emulator.

Example

The following illustration shows one of four possible orientations for connecting the QFP elastomeric probing system using the general-purpose flexible adapter.

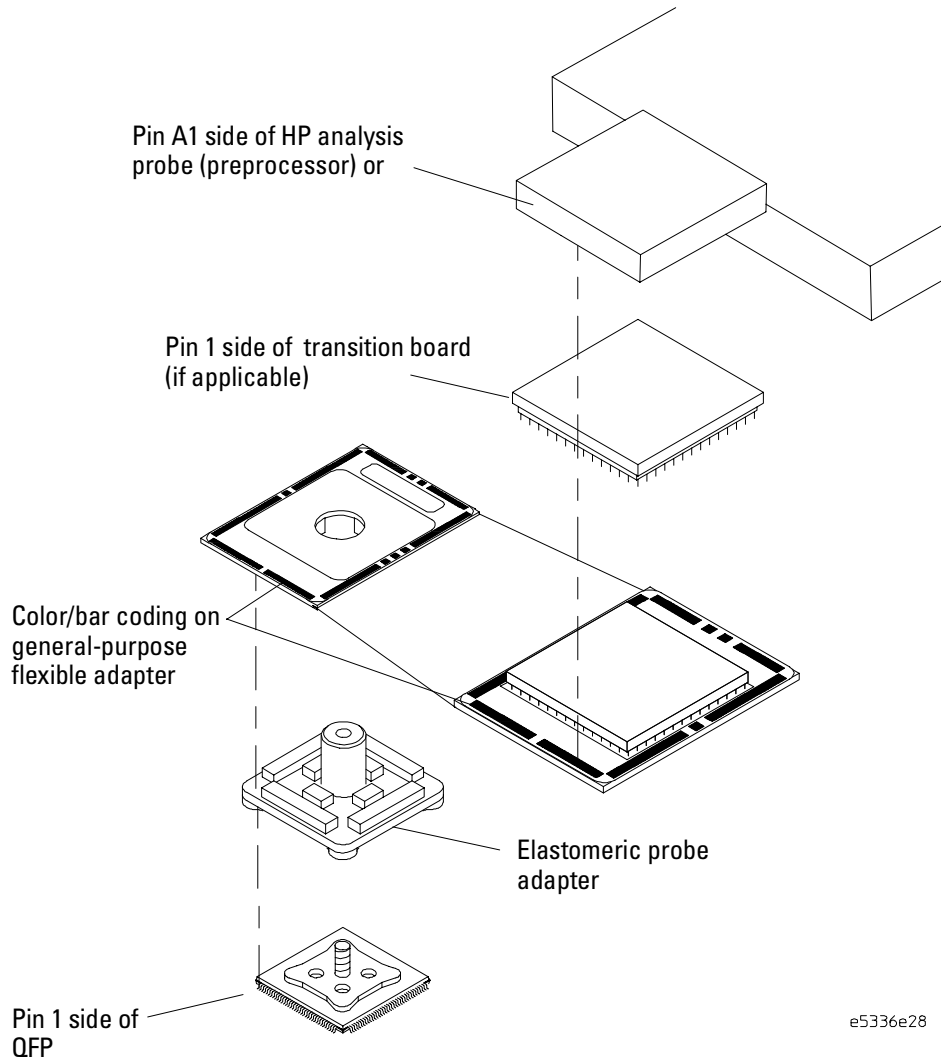

e5336e28

Refer to your HP analysis probe (preprocessor) or emulator manual to select the orientation which allows the best access to your target system.

This chapter includes the following reference information:

- Pinout and cross-reference maps
- Parts for probing additional QFPs
- Replaceable parts
- Removing retainers

Reference

Pinout and cross-reference maps

Probe adapter pinout map

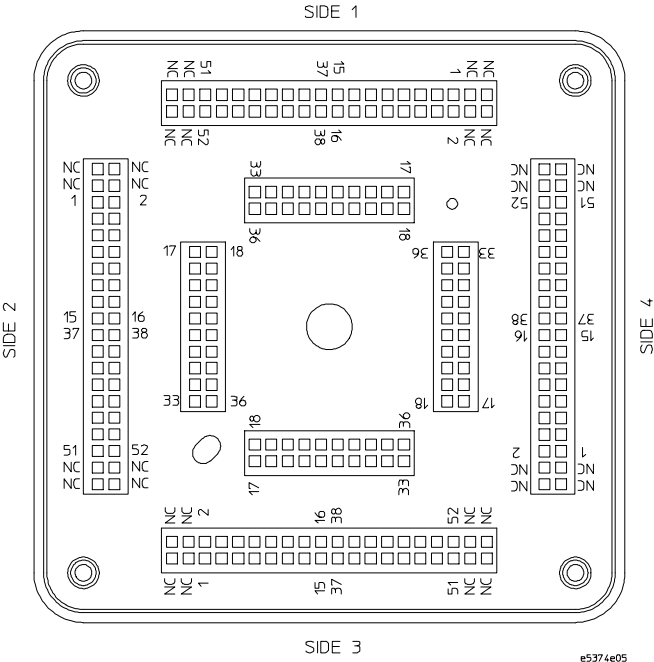

QFP pinout map

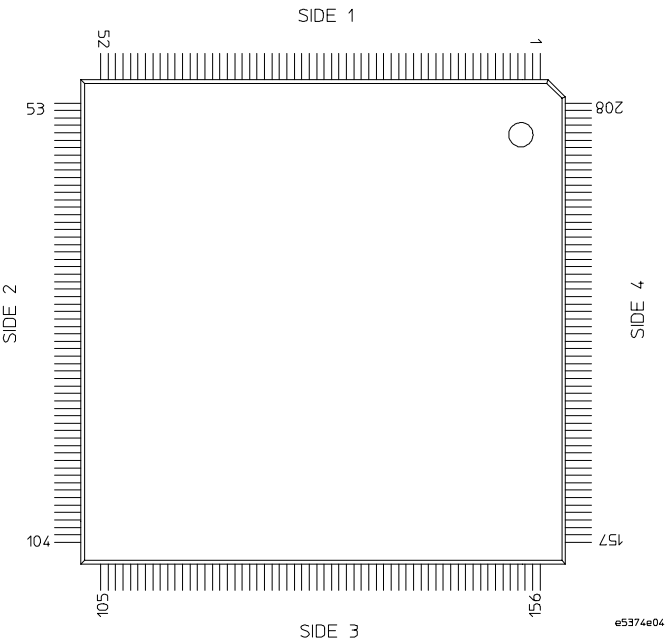

Cross reference for general-purpose flexible adapter and QFP

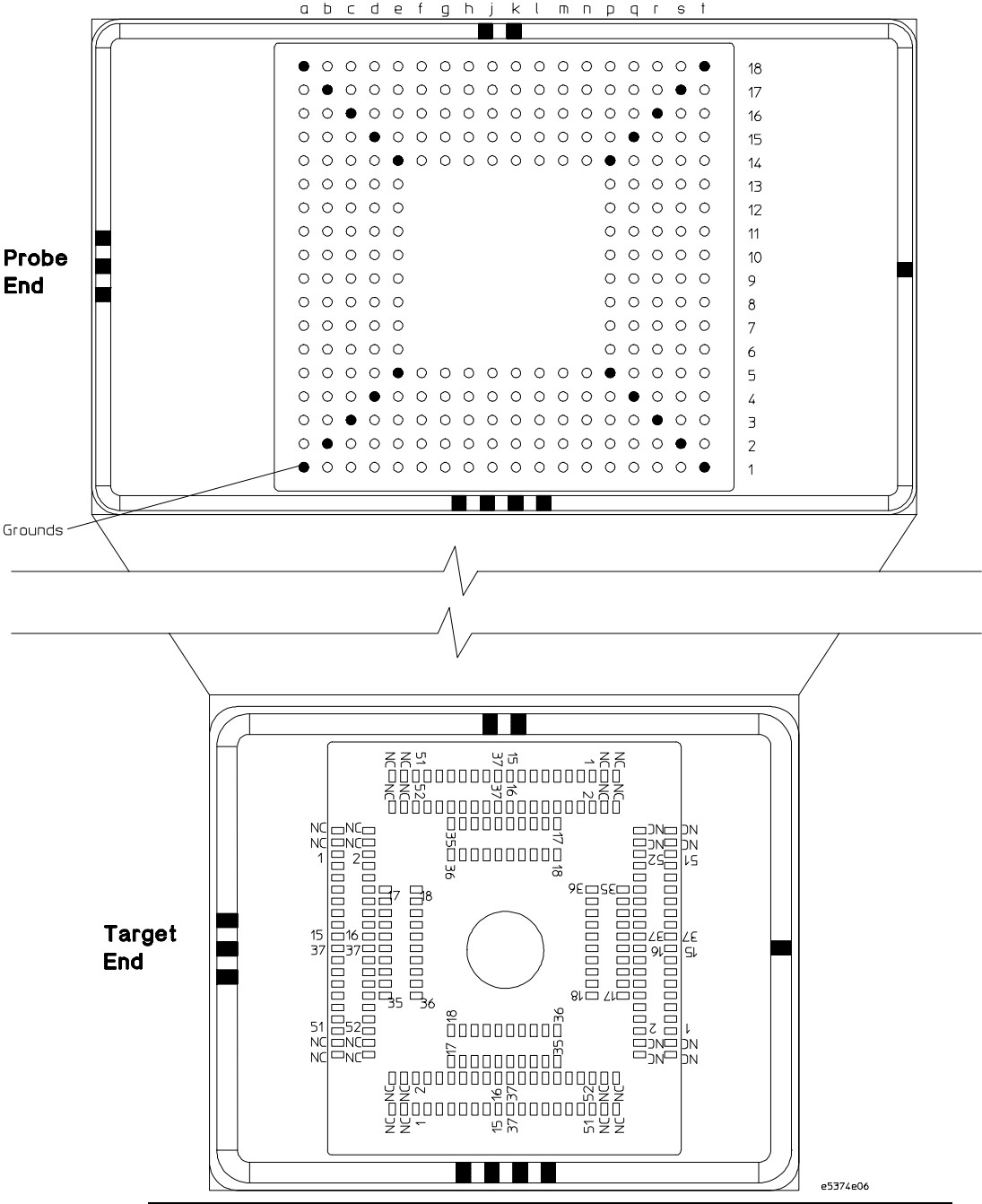

e5374e06

Reference
Pinout and cross-reference maps

Cross reference table for the QFP, probe adapter, and flexible cables

Side 1 *			Side 2			Side 3			Side 4		
QFP	Target End **	Probe End	QFP	Target End **	Probe End	QFP	Target End **	Probe End	QFP	Target End **	Probe End
NC	NC	C1	NC	NC	T3	NC	NC	R18	NC	NC	A16
NC	NC	B1	NC	NC	T2	NC	NC	S18	NC	NC	A17
NC	NC	D1	NC	NC	T4	NC	NC	Q18	NC	NC	A15
NC	NC	C2	NC	NC	S3	NC	NC	R17	NC	NC	B16
1	1	D3	53	1	R4	105	1	Q16	157	1	C15
2	2	D2	54	2	S4	106	2	Q17	158	2	B15
3	3	E2	55	3	S5	107	3	P17	159	3	B14
4	4	E1	56	4	T5	108	4	P18	160	4	A14
5	5	E4	57	5	Q5	109	5	P15	161	5	D14
6	6	E3	58	6	R5	110	6	P16	162	6	C14
7	7	F4	59	7	Q6	111	7	N15	163	7	D13
8	8	F3	60	8	R6	112	8	N16	164	8	C13
9	9	G3	61	9	R7	113	9	M16	165	9	C12
10	10	G2	62	10	S7	114	10	M17	166	10	B12
11	11	H2	63	11	S8	115	11	L17	167	11	B11
12	12	H1	64	12	T8	116	12	L18	168	12	A11
13	13	J1	65	13	T9	117	13	K18	169	13	A10
14	14	H5	66	14	P8	118	14	L14	170	14	E11
15	15	J5	67	15	P9	119	15	K14	171	15	E10
16	16	J4	68	16	Q9	120	16	K15	172	16	D10
17	17	F1	69	17	T6	121	17	N18	173	17	A13
18	18	F2	70	18	S6	122	18	N17	174	18	B13
19	19	F5	71	19	P6	123	19	N14	175	19	E13
20	20	G1	72	20	T7	124	20	M18	176	20	A12
21	21	G4	73	21	Q7	125	21	M15	177	21	D12
22	22	G5	74	22	P7	126	22	M14	178	22	E12
23	23	H3	75	23	R8	127	23	L16	179	23	C11
24	24	H4	76	24	Q8	128	24	L15	180	24	D11
25	25	J2	77	25	S9	129	25	K17	181	25	B10
26	26	J3	78	26	R9	130	26	K16	182	26	C10

* Side 1 is the side that is connected to pin 1 side of QFP

** The target end refers to the pin numbers on the probe adapter, the target end of the general-purpose flexible cable, and the 1/4 flexible cable when using more than one.

Side 1 *			Side 2			Side 3			Side 4		
QFP	Target End **	Probe End	QFP	Target End **	Probe End	QFP	Target End **	Probe End	QFP	Target End **	Probe End
27	27	K1	79	27	T10	131	27	J18	183	27	A9
28	28	K2	80	28	S10	132	28	J17	184	28	B9
29	29	K5	81	29	P10	133	29	J14	185	29	E9
30	30	L1	82	30	T11	134	30	H18	186	30	A8
31	31	L4	83	31	Q11	135	31	H15	187	31	D8
32	32	L5	84	32	P11	136	32	H14	188	32	E8
33	33	M3	85	33	R12	137	33	G16	189	33	C7
34	34	M4	86	34	Q12	138	34	G15	190	34	D7
35	35	N2	87	35	S13	139	35	F17	191	35	B6
36	36	N3	88	36	R13	140	36	F16	192	36	C6
37	37	K4	89	37	Q10	141	37	J15	193	37	D9
38	38	K3	90	38	R10	142	38	J16	194	38	C9
39	39	L3	91	39	R11	143	39	H16	195	39	C8
40	40	L2	92	40	S11	144	40	H17	196	40	B8
41	41	M2	93	41	S12	145	41	G17	197	41	B7
42	42	M1	94	42	T12	146	42	G18	198	42	A7
43	43	N1	95	43	T13	147	43	F18	199	43	A6
44	44	M5	96	44	P12	148	44	G14	200	44	E7
45	45	N5	97	45	P13	149	45	F14	201	45	E6
46	46	N4	98	46	Q13	150	46	F15	202	46	D6
47	47	P2	99	47	S14	151	47	E17	203	47	B5
48	48	P1	100	48	T14	152	48	E18	204	48	A5
49	49	P4	101	49	Q14	153	49	E15	205	49	D5
50	50	P3	102	50	R14	154	50	E16	206	50	C5
51	51	Q2	103	51	S15	155	51	D17	207	51	B4
52	52	Q1	104	52	T15	156	52	D18	208	52	A4
NC	NC	R1	NC	NC	T16	NC	NC	C18	NC	NC	A3
NC	NC	Q3	NC	NC	R15	NC	NC	D16	NC	NC	C4
NC	NC	S1	NC	NC	T17	NC	NC	B18	NC	NC	A2
NC	NC	R2	NC	NC	S16	NC	NC	C17	NC	NC	B3

* Side 1 is the side that is connected to pin 1 side of QFP

** The target end refers to the pin numbers on the probe adapter, the target end of the general-purpose flexible cable, and the 1/4 flexible cable when using more than one.

Replaceable Parts

208-Pin Part Description

- Locator Kit
- Retainer Kit
- 1/4 flexible adapter
- General-purpose flexible adapter

HP Part Number

- E5374-23801
- E5374A Opt. 201
- E5371A
- E5372A

Retainer Kit HP E5374A opt. 201

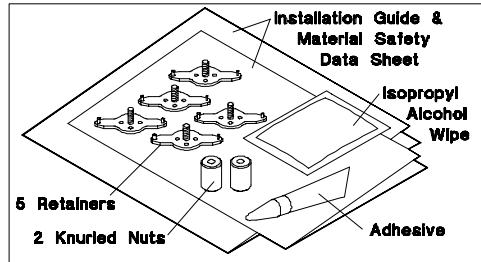

Locator Kit HP E5374-23801

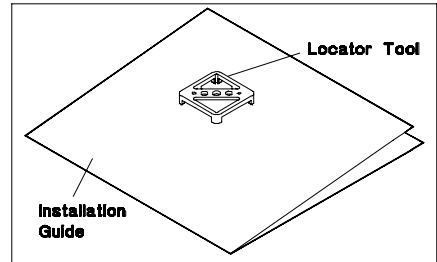

e5374e12

To remove the general-purpose flexible adapter

Gently pry the flexible adapter from the probe adapter using the pry tool as shown.

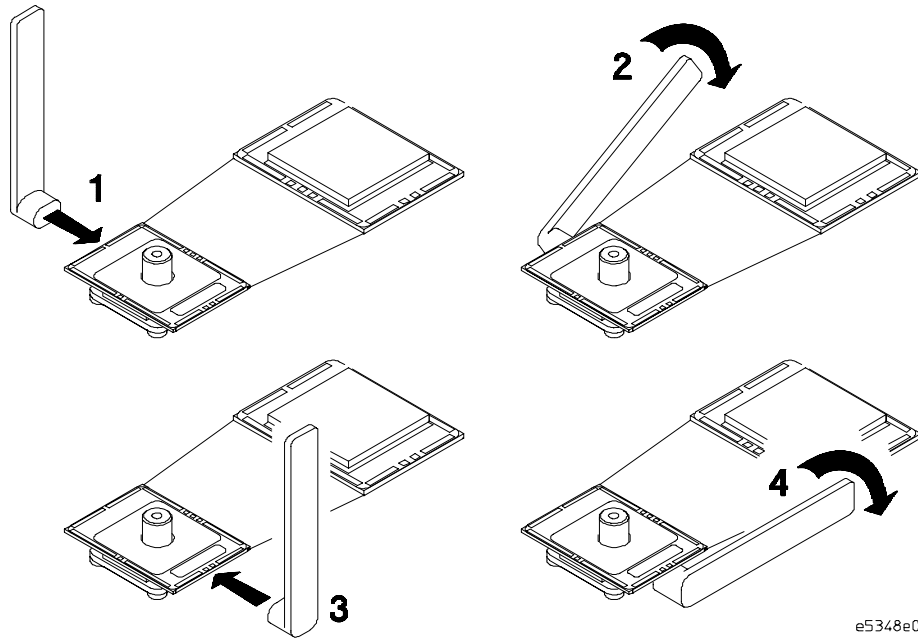

e5348e06

To remove a retainer and adhesive

WARNING

Eye injury. Use protective eye-wear during removal to avoid injury.

CAUTION

The following procedure could cause damage to some QFPs, depending upon the construction of the part and surface condition.
Power off the device under test before attempting to remove a retainer.

- 1 Use a semi-flush or full-flush cutting plier with approximately 5-inch handles, such as HP part number 8170-0006, to remove the retainer.

End view of diagonal cutting plier blades

Preferred



Full-flush

Acceptable



Semi-flush

Do not use

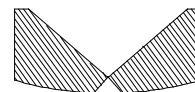

Typical

e5321e38

- 2 Place the tip of the plier against the slanted edge of the retainer.

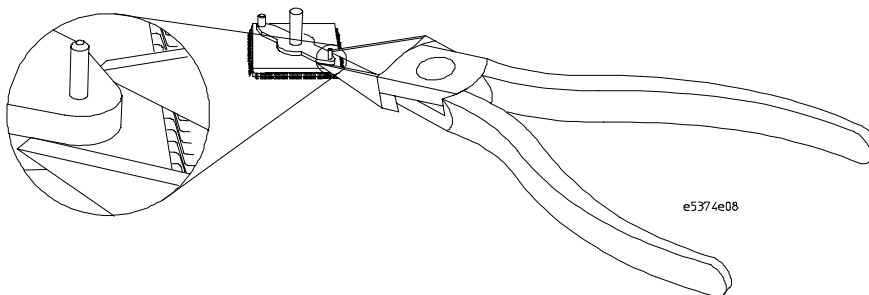

e5374e08

- 3 Ensure that the tip edge of the plier is as nearly parallel as possible and resting on the surface of the QFP.

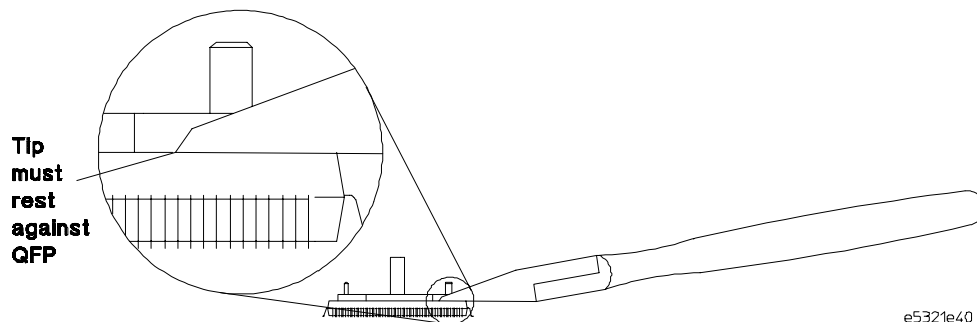

e5321e40

WARNING Possible injury. Exercise care when using any sharp cutting tool.

- 4 Hold your hand over the QFP during removal to prevent the part from flying when it pops off.

CAUTION Prevent the retainer from landing on any electrical circuits which might cause shorting.

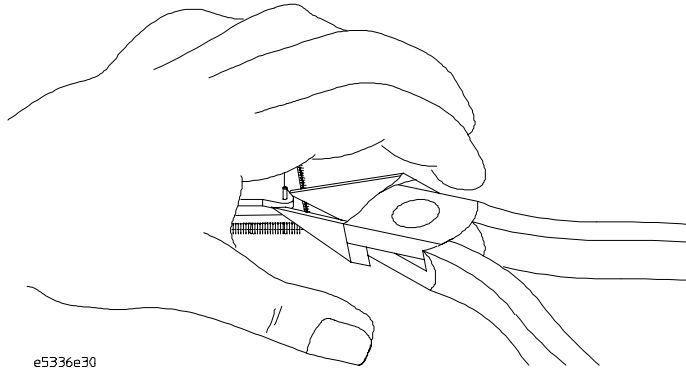

- 5 Squeeze the pliers to pop the retainer off.
- 6 Discard the retainer.

WARNING Possible injury. Exercise care when using any sharp cutting tool.

- 7 Scrape the adhesive off the top of your QFP using a single-edge razor blade or similar tool.

Do not use solvent because the solvent might dissolve the adhesive onto the leads of your QFP causing unreliable probing.

- 8 Make sure all adhesive has been removed and that there are no rough spots on the top of the QFP.
- 9 If you want to attach another retainer to your QFP, follow the installation procedure in chapter 1.

Index

0.5 mm QFP, ii

A

additional parts, 3-5
adhesive, 1-7
adhesive removal, 3-6 to 3-7
advanced probing system, ii
alignment
 flexible adapter to analysis
 probe/emulator, 2-6
 locator tool to QFP, 1-4 to 1-5
assembled locator tool, 1-4

B

bandwidth
 1/4 flexible adapter, 2-2
 QFP probe adapter, 1-2

C

capacitance
 1/4 flexible adapter, 2-2
 QFP probe adapter, 1-2
Caution
 Alignment of analysis
 probe or emulator, 2-6
 Control the amount of adhesive, 1-7
 Damage to the QFP, 2-3
 Do not over-tighten knurled nut, 1-11
 Do not touch the conductive
 elastomer, 1-10
 Power-off the device under test, 3-6
 Prevent pin damage, 2-4, 2-6
 Prevent shorting, 3-7
 Turn off the power, 1-4, 1-8
 Use grounded wrist straps, 1-4
characteristics
 1/4 flexible adapters, 2-2 to 2-4
 general-purpose flexible
 adapters, 2-5 to 2-7
 QFP probe adapter, 1-2
cleaning the QFP, 1-6, 3-7
clearance
 QFP probe adapter, 1-3
color/bar coding, 2-7
conductive elastomer, 1-10

contact resistance
 QFP probe adapter, 1-2
contamination, 1-10
cover, 1-10
current
 1/4 flexible adapters, 2-2
 QFP probe adapter, 1-2
cutting plier, 3-6

D

damage to elastomer, 1-10
dimensions
 1/4 flexible adapter, 2-2
 general-purpose flexible adapter, 2-5
 QFP probe adapter, 1-3
dowels, 1-11

E

elastomer, 1-10
electrical characteristics
 1/4 flexible adapter, 2-2
 general-purpose flexible adapter, 2-5
 QFP probe adapter, 1-2
electrostatic discharge, 1-4
environmental characteristics
 1/4 flexible adapter, 2-2
 general-purpose flexible adapter, 2-5
 QFP probe adapter, 1-2
equipment damage, 2-6
eye protection, 3-6

F

flexible adapters
 HP E5371A, 1/4 flexible, 2-2 to 2-4
 HP E5372A general-purpose, 2-5 to 2-7
frequency
 general-purpose flexible adapter, 2-5
full-flush cutting plier, 3-6

G

glue, 1-7

H

HP E5371A 1/4 flexible
 adapter, 2-2 to 2-4
HP E5372A general-purpose flexible
 adapter, 2-5 to 2-7
humidity
 1/4 flexible adapter, 2-2
 general-purpose flexible adapter, 2-5
 QFP probe adapter, 1-2

I

inductance
 1/4 flexible adapter, 2-2
 QFP probe adapter, 1-2
insulation resistance
 1/4 flexible adapter, 2-2
 QFP probe adapter, 1-2
Isopropyl Alcohol wipe, 1-6

K

knurled nut, 1-3

L

label
 160-pin 1/4 flexible adapter, 2-3
locator, 1-3
locator tool, 1-4

M

minimum clearance
 QFP probe adapter, 1-3
model parameters
 1/4 flexible adapters, 2-2
 QFP probe adapter, 1-2

O

operating bandwidth
 1/4 flexible adapter, 2-2
 QFP probe adapter, 1-2
operating current
 1/4 flexible adapter, 2-2
 QFP probe adapter, 1-2

-
- operating frequency
 - general-purpose flexible adapter, 2-5
 - operating temperature
 - 1/4 flexible adapter, 2-2
 - general-purpose flexible adapter, 2-5
 - QFP probe adapter, 1-2
 - operating voltage
 - 1/4 flexible adapter, 2-2
 - QFP probe adapter, 1-2
 - overview
 - probe adapter parts, 1-2
 - probing system, iii-ii
 - P**
 - parameters
 - 1/4 flexible adapters, 2-2 to 2-4
 - general-purpose flexible adapters, 2-5 to 2-7
 - QFP probe adapter, 1-2
 - parts
 - additional, 3-5
 - replaceable, 3-5
 - performance characteristics
 - 1/4 flexible adapter, 2-2
 - general-purpose flexible adapter, 2-5
 - QFP probe adapter, 1-2
 - Pin 1, 1-4
 - pin-to-ground capacitance
 - 1/4 flexible adapter, 2-2
 - pin-to-pin capacitance
 - 1/4 flexible adapter, 2-2
 - Probe adapter installation, 1-10 to 1-11
 - probing system, ii
 - Q**
 - QFP probe adapter, 1-2
 - Quad Flat Pack, ii
 - R**
 - relative humidity
 - general-purpose flexible adapter, 2-5
 - QFP probe adapter, 1-2
 - removing
 - adhesive, 3-6 to 3-7
 - retainers, 3-6 to 3-7
 - replaceable parts, 3-5
 - resistance
 - 1/4 flexible adapter, 2-2
 - QFP probe adapter, 1-2
 - retainer
 - adhereing to QFP, 1-7 to 1-9
 - discard used, 3-7
 - prepare to attach, 1-3
 - removal, 3-6 to 3-7
 - test alignment, 1-4 to 1-6
 - S**
 - self-inductance
 - 1/4 flexible adapter, 2-2
 - QFP probe adapter, 1-2
 - semi-flush cutting plier, 3-6
 - signal loading
 - general-purpose flexible adapter, 2-5
 - T**
 - teeth, locator, 1-4
 - temperature
 - 1/4 flexible adapter, 2-2
 - general-purpose flexible adapter, 2-5
 - QFP probe adapter, 1-2
 - V**
 - voltage
 - 1/4 flexible adapters, 2-2
 - QFP probe adapter, 1-2
 - W**
 - Warning
 - Eye injury, 3-6
 - Handling precautions for adhesive, 1-7
 - Possible injury, 3-7
-

© Copyright Hewlett-Packard Company 1997-1998
All Rights Reserved.

Reproduction, adaptation, or translation without prior written permission is prohibited, except as allowed under the copyright laws.

Restricted Rights Legend

Use, duplication, or disclosure by the U.S. Government is subject to restrictions set forth in subparagraph (C) (1) (ii) of the Rights in Technical Data and Computer Software Clause in DFARS 252.227-7013.

Hewlett-Packard Company,
3000 Hanover Street, Palo Alto, CA 94304 U.S.A.
Rights for non-DOD U.S. Government Departments and Agencies are set forth in FAR 52.227-19(c)(1,2).

Document Warranty

The information contained in this document is subject to change without notice.

Hewlett-Packard makes no warranty of any kind with regard to this material, including, but not limited to, the implied warranties of merchantability or fitness for a particular purpose.

Hewlett-Packard shall not be liable for errors contained herein or for damages in connection with the furnishing, performance, or use of this material.

Safety

This apparatus has been designed and tested in accordance with IEC Publication 348, Safety Requirements for Measuring Apparatus, and has been supplied in a safe condition. This is a Safety Class I instrument (provided with terminal for protective earthing). Before applying power, verify that the correct safety precautions are taken (see the following warnings). In addition, note the external markings on the instrument that are described under "Safety Symbols."

Warning

- Before turning on the instrument, you must connect the protective earth terminal of the instrument to the protective conductor of the (mains) power cord. The mains plug shall only be inserted in a socket outlet provided with a protective earth contact. You must not negate the protective action by using an extension cord (power cable) without a protective conductor (grounding). Grounding one conductor of a two-conductor outlet is not sufficient protection.
- Only fuses with the required rated current, voltage, and specified type (normal blow, time delay, etc.) should be used. Do not use repaired fuses or short-circuited fuseholders. To do so could cause a shock or fire hazard.

- Service instructions are for trained service personnel. To avoid dangerous electric shock, do not perform any service unless qualified to do so. Do not attempt internal service or adjustment unless another person, capable of rendering first aid and resuscitation, is present.

- If you energize this instrument by an auto transformer (for voltage reduction), make sure the common terminal is connected to the earth terminal of the power source.

- Whenever it is likely that the ground protection is impaired, you must make the instrument inoperative and secure it against any unintended operation.

- Do not operate the instrument in the presence of flammable gasses or fumes. Operation of any electrical instrument in such an environment constitutes a definite safety hazard.

- Do not install substitute parts or perform any unauthorized modification to the instrument.

- Capacitors inside the instrument may retain a charge even if the instrument is disconnected from its source of supply.

- Use caution when exposing or handling the CRT. Handling or replacing the CRT shall be done only by qualified maintenance personnel.

Safety Symbols



Instruction manual symbol: the product is marked with this symbol when it is necessary for you to refer to the instruction manual in order to protect against damage to the product.



Hazardous voltage symbol.



Earth terminal symbol: Used to indicate a circuit common connected to grounded chassis.

WARNING

The Warning sign denotes a hazard. It calls attention to a procedure, practice, or the like, which, if not correctly performed or adhered to, could result in personal injury. Do not proceed beyond a Warning sign until the indicated conditions are fully understood and met.

CAUTION

The Caution sign denotes a hazard. It calls attention to an operating procedure, practice, or the like, which, if not correctly performed or adhered to, could result in damage to or destruction of part or all of the product. Do not proceed beyond a Caution symbol until the indicated conditions are fully understood or met.

Product Warranty

This Hewlett-Packard system product is warranted against defects in material and workmanship for a period of 90 days from date of purchase. During the warranty period, Hewlett-Packard Company will, at its option, either repair or replace products that prove to be defective. Products must be returned to a service facility designated by HP.

For products returned to Hewlett-Packard for warranty service, the Buyer shall prepay shipping charges to Hewlett-Packard and Hewlett-Packard shall pay shipping charges to return the product to the Buyer. However, the Buyer shall pay all shipping charges, duties, and taxes for products returned to Hewlett-Packard from another country.

Hewlett-Packard warrants that its software and firmware designated by Hewlett-Packard for use with an instrument will execute its programming instructions when properly installed on that instrument.

Hewlett-Packard does not warrant that the operation of the instrument software, or firmware will be uninterrupted or error free.

Limitation of Warranty

The foregoing warranty shall not apply to defects resulting from improper or inadequate maintenance by the Buyer, Buyer-supplied software or interfacing, unauthorized modification or misuse, operation outside of the environmental specifications for the product, or improper site preparation or maintenance.

No other warranty is expressed or implied. Hewlett-Packard specifically disclaims the implied warranties of

merchantability or fitness for a particular purpose.**Exclusive Remedies**

The remedies provided herein are the buyer's sole and exclusive remedies. Hewlett-Packard shall not be liable for any direct, indirect, special, incidental, or consequential damages, whether based on contract, tort, or any other legal theory.

Assistance

Product maintenance agreements and other customer assistance agreements are available for Hewlett-Packard products. For any assistance, contact your nearest Hewlett-Packard Sales Office.

Certification

Hewlett-Packard Company certifies that this product met its published specifications at the time of shipment from the factory. Hewlett-Packard further certifies that its calibration measurements are traceable to the United States National Institute of Standards and Technology, to the extent allowed by the Institute's calibration facility, and to the calibration facilities of other International Standards Organization members.

About this edition

This is the first edition of the *Elastomeric Probing System for Hitachi SH7709 User's Guide*.

Publication number
E5374-9201

Printed in USA.

Edition dates are as follows:
E5374-92001, November 1997

New editions are complete revisions of the manual. Many product updates do not require manual changes and manual corrections may be done without accompanying product changes. Therefore, do not expect a one-to-one correspondence between product updates and manual updates.



HP Part Number E5374-92001
Printed November, 1998